



Raffar
Technology Corp.

2023/06 V03 (Preliminary)

RT7211

3-channel constant current LED driver with 8 bits PWM control

www.raffar.com.tw

Description

RT7211 is a 3-channel constant current LED driver with 8 bits PWM linear control. The maximum output current of each output is 11mA. RT7211 is with 16 steps current gain function to adjust the LED brightness.

The device can be programmed via an I²C compatible interface with maximum 400K Hz of the transmission speed.

RT7211 builds in Auto Breath Mode to reduce the MCU data processing. The Auto Breath Mode is with gamma effect to extend low grayscale and make a more smooth breathing effect. There are 4 timing characters that user can define to meet the breathing effect.

Applications

LED indicator

Functional light

Purchasing Information

No.	Part No.	Package
1	RT7211DN	DFN10-3x3mm

Feature

- Operating supply voltage : 3.3 V ~ 5.5 V
- Constant current output : 0.2mA ~11mA
- I²C compatible interface
- 8 bits PWM control for each output
- 16 steps current gain
- Built-in programmable breath mode
- Multi cascading capability
- Dynamic power saving function
- Accurate constant output current driving:
-Channel to Channel : $\pm 2.0\%$ (typ.)

Pin Assignment

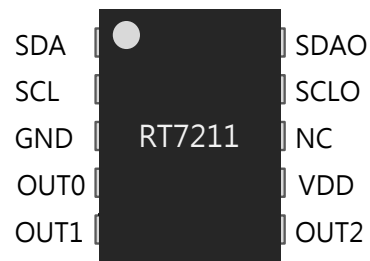

Maximum Ratings

Parameters	Symbol	Rating	Unit
Supply voltage	V_{DD}	7.0	V
Output voltage(OUT0/OUT1/OUT2)	V_{OUT}	$V_{DD}+0.5$	V
Input voltage (all pins)	V_{IN}	$-0.5 \sim V_{DD}+0.5$	V
Output current(OUT0/OUT1/OUT2)	I_{MAX}	11	mA
Operating temperature	T_{opr}	$-20 \sim +85$	$^{\circ}C$
Storage temperature	T_{stg}	$-55 \sim +150$	$^{\circ}C$

*Operating over the maximum rating conditions may cause permanent damage to the device.

*The capability of thermal dissipation is related to the dimension of thermal pad and layer numbers of the PCB.

Recommended Operating Condition

Parameters	Symbol	Rating	Unit
Supply voltage	V_{DD}	4.2~5.0	V
Input voltage (all pins)	V_{IN}	$-0.5 \sim V_{DD}+0.5$	V
Output current(OUT0/OUT1/OUT2)	I_{OUT}	0.2~11	mA

I2C Interface

RT7211 is compliance to I²C protocol to control the chip's functions with two wires: SCL and SDA. After the "Start" signal, user has to send the address of IC which is 7'b0010101. The data sequence is shown below.

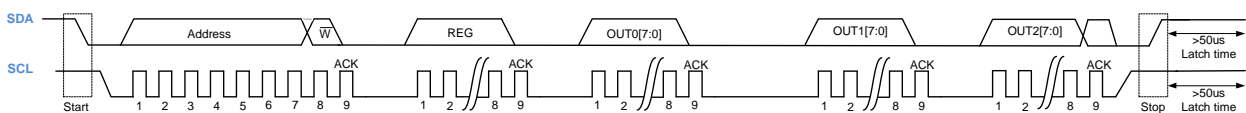

Typical Application Circuit

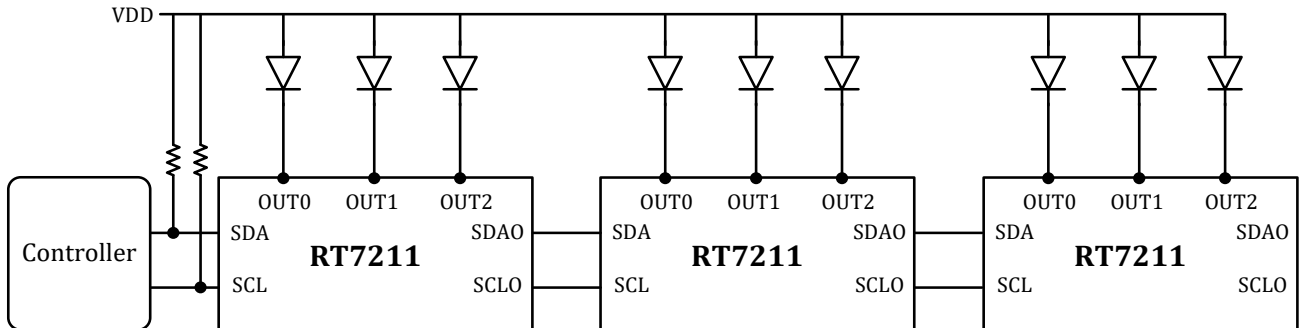

Note 1 : The pull-up resistors of SCL and SDA between the Controller and the first chip must be added on board to ensure the stable waveform of signal in different applications.

Note 2 : The bypass capacitor on VDD pin of each IC is necessary to be added on board for the stability of chip operation. The suggested value of capacitor is 0.1uF.

Note 3 : I2C is a two-way communication application. it is recommended to add a digital isolator, such as ADuM1250, between the first IC and MCU SDA/SC on bus line 3.3V to 5V. The reference circuit is as follows.

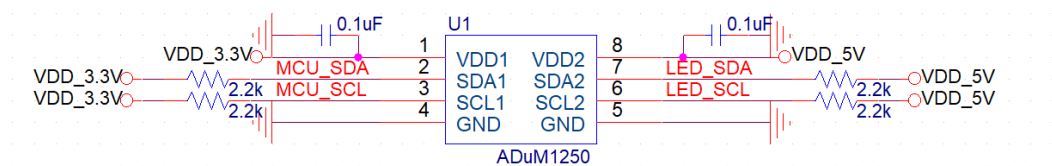

Package Outline Drawing

DFN 10 3 x 3mm

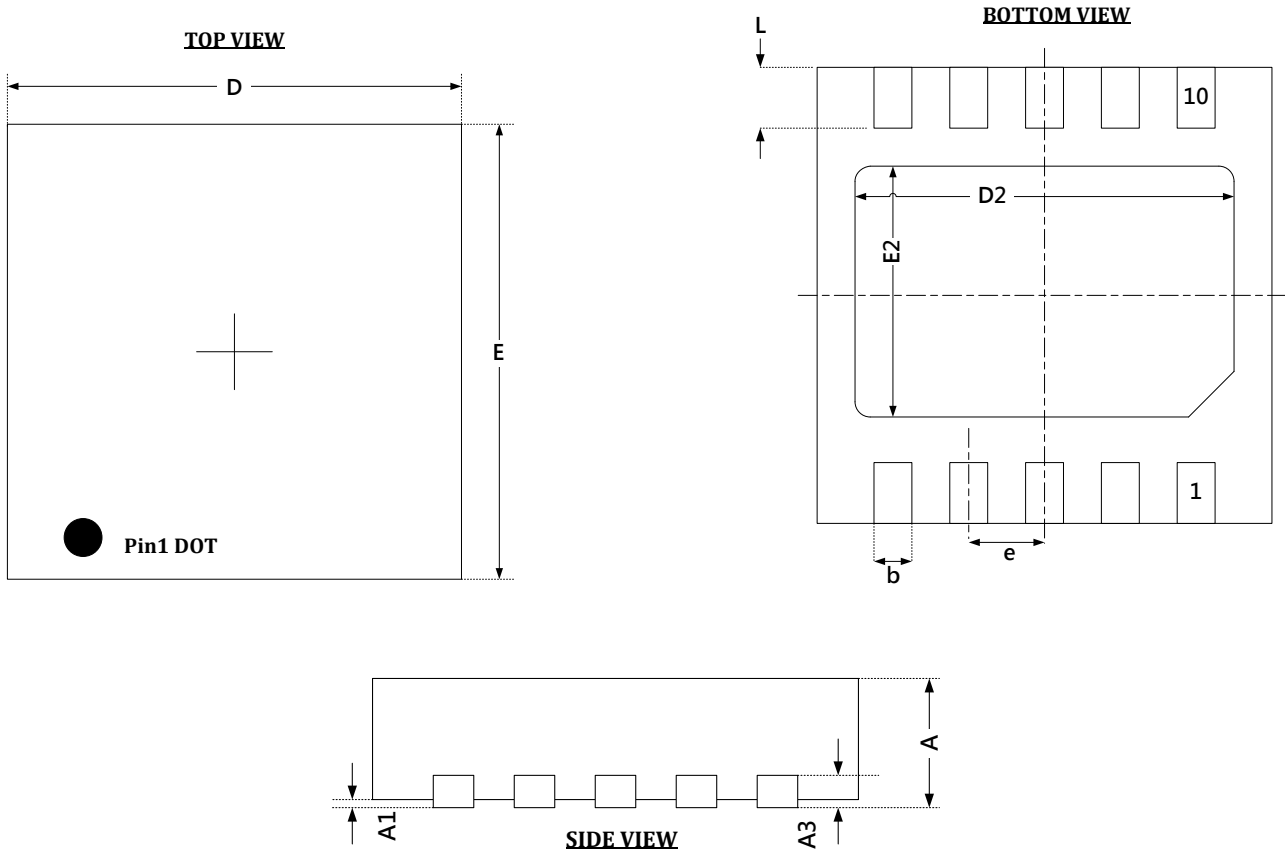

Symbol	Millimeters(mm)	
	Min.	Max.
A	0.70	0.80
A1	0.00	0.05
A3	0.203(REF)	
b	0.18	0.30
D	2.90	3.10
D2	2.40	2.60
E	2.90	3.10
E2	1.50	1.70
L	0.35	0.45
e	0.45	0.55



Notice

The contents of this document are provided in connection with Raffar Technology Corporation products. Raffar reserve the right to make corrections, modifications, improvements, and other changes to the specifications and product descriptions at any time without notice.

Raffar products are not authorized, designed or intended for use in military/ aerospace/ automotive/ atomic energy control instruments applications or environment, or for other applications intended to support or sustains life. Raffar customer using and selling these products for use in such applications do so at their own risk. Raffar will not be responsible for any failure to meet such requirements