



Raffar
Technology Corp.

Raffar Technology Corp.

RT5956

Built-in Swift Register 4-channel 5A PMOS with Anti-ghosting Control

2021/03

Version: 0.7

Description

RT5956 is an integrated 4-channel PMOS outputs for high refresh rate LED display applications to eliminate the LED ghosting phenomena. By controlling the BK signal timeslot (LED discharge), the RT5956 is not only to prevent LED cascading blink which caused by an LED open or short damage, but also to avoid the over reverse voltage to damage LEDs on display performance. The RT5956 gives a very simple control model to let controller determined the turn-on, discharge, and row blank timing. Built in the 8-bit shift register, RT5956 make the data transfer by serial connection without decode components on board, this also do the help on fine pitch LED display PCB layout.

The RT5956 support 5A current output for each channel.

Features

- 5A large current output for outdoor display (parallel two outputs)
- Built-in anti-ghosting function
- Eliminate the LED cascading blink by LED short.
- Eliminate the LED cross blink by LED open (alternative)
- Serial Data connection transfer for easy and simplified PCB layout
- Wipe off 138 decoder

Application

Indoor and Outdoor large current LED display

Order Information

No.	Part No.	Package
1	RT5956SP	SOP16-150 mil-1.27 mm
2	RT5956QN	QFN16 – 4mm*4mm

Pin Assignment

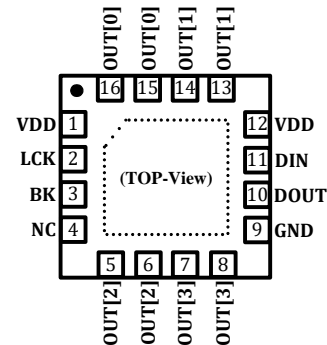
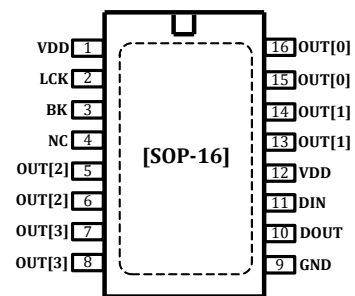

Pin No.	Pin Name	Description
1, 12	VDD	Power supply
2	LCK	Serial data strobe input
3	BK	Discharge enable control
4	NC	No connection
5, 6, 7, 8, 13, 14, 15, 16,	OUT[0:3]	Current output[0:3]
9	GND	Ground Terminal
10	DOUT	Serial data output
11	DIN	Serial data input

Recommend Application Circuit

To have the best performance of fine pitch LED display, RT5956 provides the discharge circuit to eliminate the ghosting from LED row. However, there is also a slight LED ghosting from the LED column which needs to use the LED driver with pre-charge function to achieve the non-ghosting display performance. (Pre-charge LED driver, like RT5965)

By controlling the BK signal timeslot, the RT5956 can effectively avoid the over reverse voltage to damage LEDs and can improve the LED cascading bright line caused by a defected LED.

RT5956 is a 4 outputs PMOS with high power loading. The IC temperature has to be monitored in practical use.

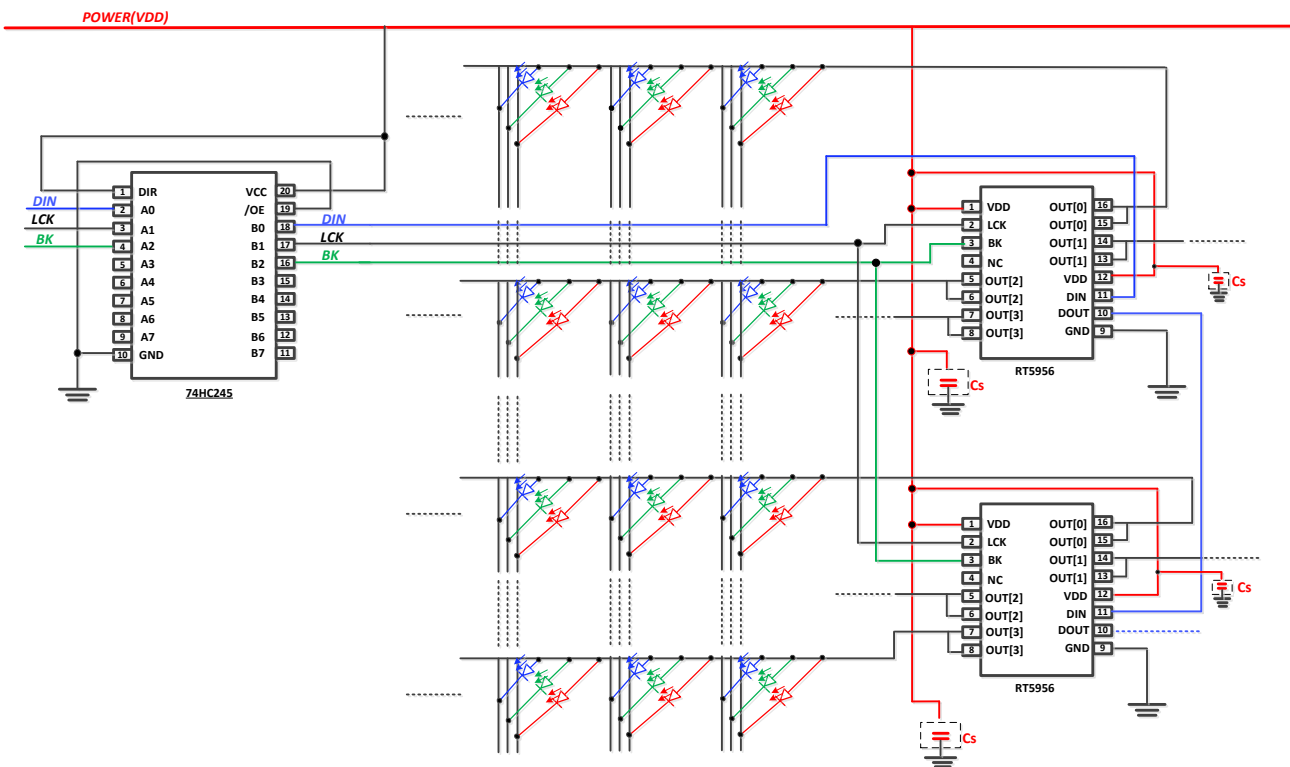

【 Serial Connection 】

Remark:

Cs is the by-pass capacitor of RT5956. Please put the Cs as close as possible to the VDD pins of RT5956 to enhance the stability of power signal. The suggested value of Cs is 1uF.

Note

The contents of this document are provided in connection with Raffar Technology Corporation products. Raffar reserve the right to make corrections, modifications, improvements, and other changes to the specifications and product descriptions at any time without notice.

Raffar products are not authorized, designed of intended for use in military/ aerospace/ automotive/ atomic energy control instruments applications or environment, or for other applications intended to support or sustains life. Raffar customer using and selling these products for use in such applications do so at their own risk. Raffar will not be responsible for any failure to meet such requirements.